

SIEMENS



Refrigerant valves

Valves for precise control and optimum energy efficiency
in refrigeration systems

Answers for infrastructure.



MVL661..



MVS661..N and matching ASR valve insert

The new generation – MVL661.. and MVS661..N

MVL661..
This fine-tuned valve series has an expansion capacity range of 29 to 737 kW.

Wide range of application areas
MVL661 and MVS661..N cover the three application areas of expansion, hot gas and suction throttle. As such, just one valve series covers all common safety refrigerants. With protection class IP65

(water jet protection), the valves can even be installed in food processing areas.

Thanks to their piston construction and valve housing cast in one piece from CrNi steel, the MVL661 and MVS661..N are robust and maintenance-free. The minimum opening, in other words the bypass function for suction throttle, is selectable on the electronics housing.

Type	DN [mm]	k_{vs} [m ³ /h]	Qo E [kW]	Qo H [kW]	Qo D [kW]
MVL661.15-0.4	15	0.40	47	9.2	1.7
MVL661.15-1.0 ¹⁾	15	0.63	74	14	2.6
MVL661.15-1.0	15	1.0	117	23	4.2
MVL661.20-2.5 ¹⁾	20	1.6	187	37	6.6
MVL661.20-2.5	20	2.5	293	57	10
MVL661.25-6.3 ¹⁾	25	4.0	468	92	17
MVL661.25-6.3	25	6.3	737	144	26
MVL661.32-12 ¹⁾	32	8	²⁾	²⁾	33
MVL661.32-12	32	12	²⁾	²⁾	50

Qo E Refrigeration capacity in expansion applications

Qo H Refrigeration capacity in hot gas bypass applications

Qo D Refrigeration capacity in suction throttle applications

Qo with R407C at to = 0 °C, tc = 40 °C and Δp = 0.5 bar

¹⁾ Valve stroke electronically limited to 63%

²⁾ MVL661.32-12 is only approved for suction throttle applications

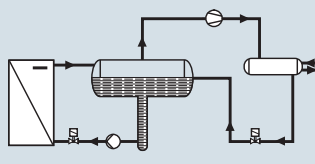
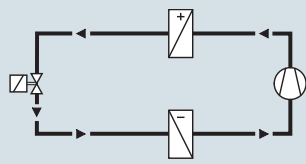

Expansion applications
using MVL661 + MVS661..N

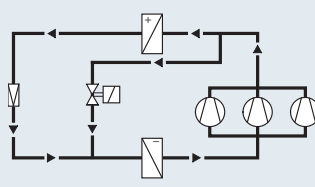
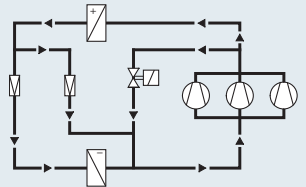

Hot gas applications
using MVL661 + MVS661..N

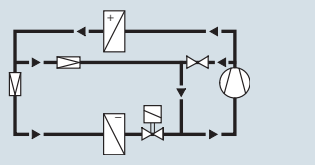
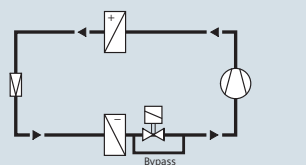

Suction throttle applications
using MVL661 + MVS661..N

Innovative technology offers a host of user benefits

The high-resolution stroke allows for precise evaporator control. The control performance is unique under all load conditions and extremely stable even in the short-stroke range. The fast positioning time of less than a second controls even complex systems with plate heat exchangers and small quantities of refrigerant safely and precisely. With four selectable control signals DC 0/2...10 V, 0/4...20 mA, the MVL661 and MVS661..N are compatible with the most common controllers. The stroke position feedback signal can be utilized for process monitoring. In the event of a power failure, the valves close thereby ensuring maximum safety.

Accurate positioning thanks to the high-resolution stroke allows precise capacity control. The internal stroke control loop compensates for non-linearity and hysteresis. The maximum permissible pressure difference Δp_{\max} of 25 bar and the maximum permissible operating pressure of 53 bar allow the use of many types of refrigerant and can be used in applications with high pressure difference between the high-pressure and low-pressure side of the refrigeration system.

Economical operation

Compared to thermostatic expansion valves, the amortization time is less than one year. This is thanks to precise superheat control under all load conditions. The integrated mechanical close function saves additional system components. The integrated valve electronics housing with selectable control signals simplifies installation and commissioning. And as only one valve is needed to cover expansion, hot gas and suction throttle applications, it is easier to manage parts storage. In addition, the electronics housing is integrated and included in the price.

MVS661..N

This valve was developed for ammonia refrigerant applications.

An exchangeable valve insert allows various k_{vs} values to be covered using a DN25 valve.

For servicing, the valve insert can also be exchanged on site if the necessary precautions are taken.

Highlights

MVL661../MVS661..N

- Hermetically sealed
- Solder connection
- One valve type, 3 applications
- MVL661.. has 5 k_{vs} values
- Fast positioning time (< 1 s)
- Selectable standard interface DC 0/2...10 V or 0/4...20 mA
- Exchangeable electronics housing
- Closed when deenergized (NC)
- MVL661.. special Ex protection edition available on request

MVS661..N as MVL661.. plus

- Valve for ammonia and CO₂ applications
- Welding connection
- One size, 5 k_{vs} values
- Exchangeable ASR.. valve inserts

Exchangeable ASR inserts for MVS661..N:

ASR0.16N = 0.16 m³/h

ASR0.40N = 0.4 m³/h

ASR1.0N = 1.0 m³/h

ASR2.5N = 2.5 m³/h

ASR6.3N = 6.3 m³/h



M3FB..LX

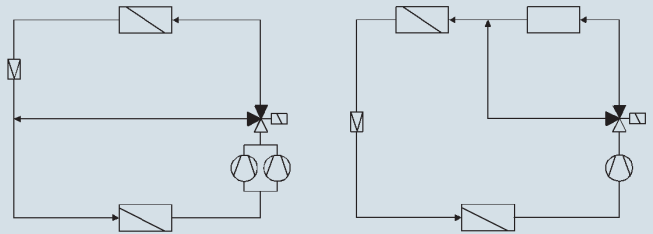

M3FB..LX and M3FK..LX

The M3FB..LX can be used as a diverting or straight-through valve for continuous capacity control in compression refrigerant systems and for heat recovery.

Indirect hot gas bypass

In this application, the control valve reduces the capacity of a compressor stage. The hot gas is fed directly to the evaporator and allows the capacity to be adjusted from 100% down to 0%. This application is suitable for large air conditioning systems where excessive temperature fluctuations occur between each compressor stage. In doing so, this ensures the system functions correctly under all load conditions.

Indirect hot gas bypass also makes it possible to heat without requiring an additional heat exchanger. Application areas include ripening chambers or containers. In addition, the indirect hot

gas application can be used for hot gas defrosting of cooling coils. Compared to mechanical hot gas valves, the M3FB..LX excels thanks to its more precise evaporation temperature and pressure control.

Direct hot gas bypass

The control valve reduces the capacity of a compressor stage. The gas is fed through to the suction line of the compressor and cooled by an injection valve. This application is suitable for larger air conditioning systems with multiple compressors. It allows a high evaporation pressure to be maintained with reduced capacity thereby preventing the cooling coils from frosting up. The application is similar to suction throttle control, but covers a wider capacity range. The M3FB..LX allows the suction pressure for the compressor to be controlled more accurately compared to using mechanical hot gas valves.



M3FK..LX

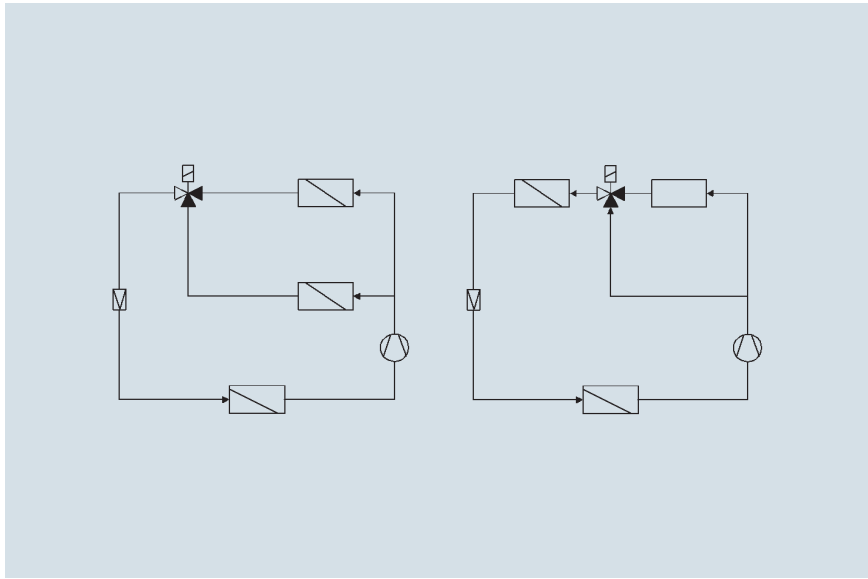

Heat recovery

Various applications using multiple condensers can be realized using the hot gas bypass valve. While the additional condenser or gas cooler removes heat according to demand, the unwanted heat is discharged via the main condenser. Typical applications include producing warm water and preheating of air. These applications save energy and costs when generating heat.

The M3FK.LX can be used as a mixing or straight-through valve to continually regulate the capacity of condensers.

It can be used either on the liquid or gas side. Assorted types of heat recovery system can be equipped with the condenser control valve. Compared to hot gas applications, much higher capacities can be controlled on the condensate side with a similarly sized valve. The diagram on the left shows the condensate control of an auxiliary condenser. This application is suitable for preheating, domestic hot water preparation or low-temperature heating systems. Up to 1000 kW can be controlled per valve. The diagram on the right side shows the gas-side control of condensers connected in series. This application is suitable for air reheaters.

Two-way applications

The nominal diameters 40 mm and 50 mm are also used as suction valves. In doing so, the lower port 2 is closed.

Highlights

M3FB..LX/M3FK..LX

- Hermetically sealed
- Positioning time < 1 s
- AB -> A/1-3 closed when deenergized
- High resolution and accuracy of control
- Selectable ZM.. electronics housing: DC 0...10 V, 4...20 mA, 0...20 V Phs
- For safety refrigerants
- M3FK..LX as an extension to the MVL661.. series, DN40 and DN50 for suction throttle applications

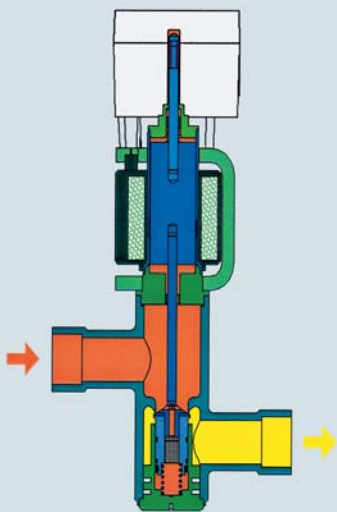

Proportional magnet for refrigerant valves

Proportional magnet as an actuator for refrigerant valves.

Over 30 years of experience

For over 30 years, Siemens has been developing and producing refrigerant valves with magnetic actuators. Today, our range includes four valve ranges of 25 different types. The one thing they all have in common is the actuator technology: the ultra precise, permanent DC magnet.

Environment and safety

All our valves save energy in refrigeration systems thanks to precise control even in the partial load operation. The valves are hermetically sealed and are therefore safe for the environment.

The magnetic plunger in all actuators is completely housed in a pressure tube. The coil is outside the refrigerant loop making the system hermetically sealed. The magnetic coil generates a magnetic field that is transmitted by the pressure tube causing the plunger to change position thus causing the valve to stroke.

Consequently, refrigerant valves from Siemens neither have static nor dynamic seals which could allow refrigerant to escape into the environment in the event of damage.

Proportional versus ON/OFF

In its basic design, the proportional permanent DC magnet is similar to a solenoid valve that is controlled by pulse width modulation. However, it has considerable additional benefits: as the valves are continually adjusting, hydraulic hammering is prevented which would otherwise lead to noise, vibration or even system damage. A positive impact on service life is due to the fact that proportional solenoids do not need to utilize the valves full stroke.

Proportional valves offer very good control even in the partial load operation. Solenoid valves controlled by pulse width modulation have a relatively high minimum throughput as the opening time cannot be controlled to as short a time as required. This makes control more difficult in the partial load.



PolyCool CPS40 superheat controller set

Want to save energy and improve the performance of your refrigeration system? With the PolyCool™ superheat controller set CPS40, you can easily achieve energy savings of up to 25% and increase cooling capacity at the same time.

Save time and energy

The PolyCool superheat controller set CPS40 is impressive as it is simple to install and can be configured directly on site thanks to its integrated user interface. With the PolyCool superheat controller set, you can achieve energy savings of up to 25% through precise super heat control.

The electronic expansion valve optimizes the refrigerant charge in the evaporator, enables smaller superheat. The higher evaporating pressure increases the COP of the system which leads to a reduction in energy consumption.

Highlights

- Four capacity classes with a refrigeration capacity range between 20 – 740 kWh
- Safety switch-off for compressors
- Limitation of evaporating pressure (MOP)
- True superheat control through pressure and temperature monitoring
- Optimal control algorithm for minimum superheat
- Up to two independent superheat control loops
- Valve starting action adjustable in terms of time and degree of opening

Technical data

	MVS661..N	MVL661..-...	M3FB..LX..	M3FK..LX..
Operating voltage	AC 24 V/DC 20...30 V	AC 24 V/DC 20...30 V		
Power consumption	22 VA	22 VA		
Control signal	DC 0/2...10 V, 0/4...20 mA	DC 0/2...10 V, 0/4...20 mA		
Positioning time	< 1 s	< 1 s	< 1 s	< 1 s
Emergency positioning function	Closed	Closed	AB-A closed	1->3 closed
Position feedback	DC 0/2...10 V, 0/4...20 mA	DC 0/2...10 V, 0/4...20 mA		
Protection class	IP65	IP65		
Ambient temperature	-25...+55 °C	-25...+55 °C	-40...+50 °C	-40...+50 °C
Installation position	Upright to horizontal	Upright to horizontal	As desired	As desired
Permissible operating pressure	5300 kPa	4500 kPa	4300 kPa	3200 kPa
Δp_{\max} control port 1->3 A->AB	2500 kPa	2500 kPa DN32: 200 kPa	See table 1	gas: 800 kPa liquid: 200 kPa
Δp_{\max} bypass port 1->2			800 kPa	gas: 800 kPa liquid: 200 kPa
Control port leakage rate 1->3/A->AB	Max. 0.002% of k_{vs} value	Max. 0.002% of k_{vs} value	Max. 0.05% of k_{vs} value	Max. 0.05% of k_{vs} value
Bypass port leakage rate 1->2			Max. 0.5% of k_{vs} value	Max. 0.5% of k_{vs} value
Medium temperature	-40...+120 °C	-40...+120 °C	-40...+120 °C	-40...+120 °C
Valve characteristic	Linear	Linear	Linear	Linear
Stroke resolution $\Delta H/H100$	1:1000	1:1000	1:200	1:200
DN [mm]	25	15-32	15-32	15-50
k_{vs} [m ³ /h]	0.16-6.3	0.4-12	0.6-12	0.6-30
Valve body	Stainless steel	Stainless steel	Steel	Steel
Inner fitting	Stainless steel, teflon	Stainless steel, brass, teflon	Brass, stainless steel	Brass, stainless steel
Data sheet	CE2N4716	CA2N4714	CA2N4721	CA2N4722
		a)	b)	b)

a) DN32 only for suction gas applications

b) ZM electronic interface must be ordered separately. See table 2

Table 1	Δp_{\max}
Typ	[kPa]
M3FB15LX06/A	2200
M3FB15LX15/A	2200
M3FB15LX/A	2200
M3FB20LX/A	1800
M3FB25LX/A	1200
M3FB32LX	800

Table 2	ZM101/A	ZM121/A	ZM111
Operating voltage	AC 24 V	AC 24 V	
Positioning signal	DC 0...10 V	4...20 mA	Phs 0...20 V
Protection class	IP54	IP54	IP54



Siemens Switzerland Ltd
Infrastructure & Cities Sector
Building Technologies Division
International Headquarters
Gubelstrasse 22
6301 Zug
Switzerland
Tel +41 41 724 24 24

The information in this document contains general descriptions of technical options available, which do not always have to be present in individual cases. The required features should therefore be specified in each individual case at the time of closing the contract.

© Siemens Switzerland Ltd, 2013 • Order no. 0-92308-en • 0,351302

Answers for infrastructure.

Our world is undergoing changes that force us to think in new ways: demographic change, urbanization, global warming and resource shortages. Maximum efficiency has top priority – and not only where energy is concerned. In addition, we need to increase comfort for the well-being of users. Also, our need for safety and security is constantly growing. For our customers, success is defined by how well they manage these challenges. Siemens has the answers.

“We are the trusted technology partner for energy-efficient, safe and secure buildings and infrastructure.”